

MY 4-H Sheep Project Record Book

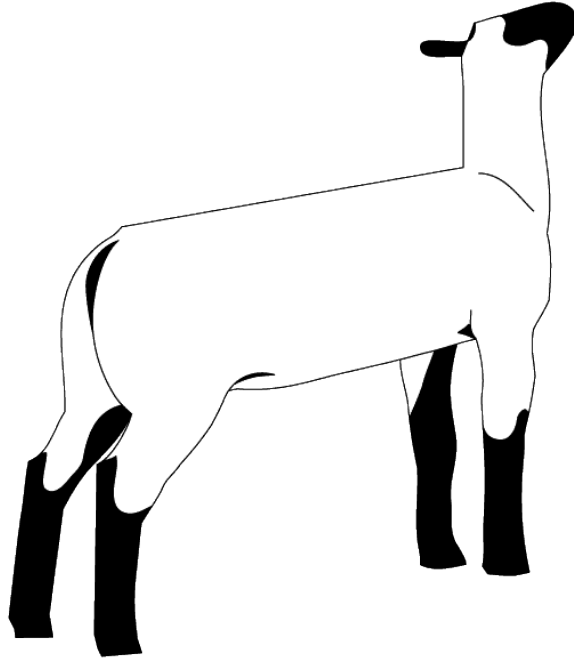

Member Name _____

Birthdate ___ / ___ / ___ Grade Completed: _____

Address: _____

Phone: _____ 4-H County _____

Years in Project: _____ 4-H Year _____

Club Name _____

Club Leader's Name _____

Introduction

This project record book has been created specifically for members involved in the 4-H Sheep Project. Keeping this record book will help you learn how to organize yourself and learn the importance of always keeping records even if it seems like a chore. Hopefully with this book you learn both of these skills as well as many other important skills.

Goals of the 4-H Sheep Project

Through participation in this project, youth will:

- Practice the life skills of
 - Decision Making
 - Communicating with Others
 - Planning and Organizing
 - Learning to Learn
- Identify and select quality sheep
- Demonstrate good sheep management and health practices
- Develop sheep showing, sportsmanship, and fitting skills
- Improve their lamb consumer skills
- Promote sheep products and the sheep industry

Guidelines for the 4-H Sheep Project Record Book

One record book can be used for all of your project animals. This record book is designed to start at the beginning of the 4-H year and all expenses and receipts during the year should be kept for records. It would behoove you to keep this record book up to date at least monthly as well as keeping it neat, complete, and accurate.

The year should start by setting at least three goals for the upcoming project year. These goals should pertain to gaining new knowledge and skills that will better your sheep experience or help in gaining life skills.

End of Year Signatures

At the conclusion of the 4-H year, when this record book is complete, your 4-H club leader will need to see this record book to make sure that it is neat, complete, and accurate.

By signing below, I am stating the I have completed this record book myself and to the best of my knowledge, the information contained in it is correct.

4-H Member Signature	Date

By signing below, I am stating that I am familiar with this work and, to the best of my knowledge, the member completed this record book and the information included in it is correct.

Title	Signature	Date
Parent		
4-H Club Leader		



Starting Out

My goals for the 4-H Year

List some goals for the year that you plan to accomplish. Try to pick realistic goals that you will be able to reach within the 4-H year. During each year in this project members should pick at least three goals to pursue. You are more than welcome to try and reach more goals. For each goal you need to write a short plan of action of what you need to do to reach the goal. Please write your choices below. Do not forget to get the required signatures.

My Goals For This Year	Plan of Action
Example: I will learn how to give a public presentation	Attend county public presentation workshop. Have my leader and parents help me pick a topic that is good for me. Practice my presentation. Give a presentation at a club meeting.

Signatures for Goal-Setting

I will work toward the above goals I have set for myself for the upcoming 4-H year to the best of my ability:

_____ Member Signature _____ Date

I will support my child's goals for the upcoming 4-H year:

_____ Parent Signature _____ Date

I will support this member's goals for the upcoming 4-H year:

_____ Leader Signature _____ Date

Along the Way

Keeping Track of What I Do

For this section, it is best to write down what you have done immediately after finishing it so you will not forget important events and activities. This is the section of the record book where you record what you did throughout this 4-H year. It is important to keep a record of what you did in case you ever need to reference a certain event or activity.

Events that should be included in this record:

- Events participated in
- Special meetings & clinics
- Community Service
- County 4-H Fair
- Shows & Competitions
- Public Speaking

Every record should contain the following

- Date: The date the event was held
- Name of the Event
- What was done: What did the member do and learn at the event
- Level: Whether the event was held at the Club, County, State, Regional, or National levels

Example:

Date	Activity Name	What Was Done	Level
<i>7/21/10</i>	<i>Club Meeting</i>	<i>Finalized the Booth for the Fair</i>	<i>Club</i>
<i>8/12/10</i>	<i>County Fair</i>	<i>Showed my project animal and market lamb</i>	<i>County</i>

You may also include show records in this section. You can record them as individual animals or per show.

Date	Activity Name	What Was Done	Level
<i>8/12/10</i>	<i>County Fair</i>	<i>Fluffy- Purebred Aged Meat Ewe Class 2nd of 8</i>	<i>County</i>
<i>Show Record for Bonnie</i>			
<i>9/12/10</i>	<i>Garden State Sheep Breeders</i>	<i>Purebred Aged Wool Ewe Class 1st of 9</i>	<i>Regional</i>
<i>10/16/10</i>	<i>New York Sheep Show</i>	<i>Purebred Aged Romney Ewe Class 3rd of 19</i>	<i>Regional</i>

Date	Activity Name	What Was Done	Level

(You may add more copies of this page as needed)

Flock Record - Sheep Inventory

For this project you will need to keep track of the sheep in your flock. This includes sheep you own or lease at the beginning of the year and all the sheep at end of the project year. For each sheep please list its name/flock number, registration number (if registered), breed, date of birth or age, date of purchase, how the animal left the flock & date, sex (ewe=E, ram=R, wether=W) and value. Value is the amount the animal was purchased for but can increase or decrease based on the condition of the sheep from the beginning of the year compared to the end. If you have a large flock you should record your project animals.

Sheep's name/ flock #	Registration #	Breed	Date of Birth	Date of Purchase	How animal left flock & date	Sex	Value	
							Proj. Start	Proj. End
Ex. Fluffy	79324	Romney	3/14/05	Gift, Flock Lamb, or Bought 8/23/07	Sold 4/26/10	E	\$120	\$125
Total Value of Sheep(add all values of sheep and put these numbers in the boxes at right							Start	End

(You may add copies of this page as needed)

Net Value _____
(End minus Start)

Barn Equipment and Supplies Inventory - Start of Project Year

This is the section where all of your barn equipment and supplies are recorded. At the start of the project year you should inventory your supplies to see what you have and what you need. If the cost is not known, you may estimate the cost. This page is very helpful if supplies are lost, destroyed, or stolen. When you purchase new equipment and supplies, list these items on this page and the cost in the expenses section of this record book. Value is the amount of money that the object is worth it can decrease based on the condition of the object.

Year Acquired	Item Description	Cost - If Purchased	Value
2005	Example: 5 - 1 gallon water buckets	\$25.00	\$23.00
Total Value of Equipment & Supplies (Add all values of Equipment and Supplies and put this number in the box at the right)			

Project Finances

Expenses

Expenses is the money that it takes to keep your sheep project running. Expenses can be broken down into four major sections: Feed, Equipment, Sheep Purchases, and Miscellaneous. A description of each is provided at the beginning of each section.

Feed Expenses

Feed expenses include all costs related to the feeding of your animals. This includes buying feed, hay or any other feed supplement. Make sure you save your receipts in order to keep more accurate feed records. For each month please provide the amount of bags purchased and the price per bag, amount of hay and price per bale, and the total for each month.

Month	# of bags bought	Price per bag	# of hay bales	Price per bale	Total per month
<i>Example:</i>	<i>10</i>	<i>\$8.50</i>	<i>2</i>	<i>\$30</i>	<i>\$145</i>
Sept.					
Oct.					
Nov.					
Dec.					
Jan.					
Feb.					
Mar.					
Apr.					
May					
Jun.					
Jul.					
Aug.					
Total Feed Expense (add totals of months to get total feed expense)					(E1)

Equipment Expenses

Equipment expenses include any costs that relate to the purchase of any new equipment. These can include new halters, buckets, fitting stands, etc.

Date	Item Description	Cost/Price
<i>9/15/10</i>	<i>black 5-gallon buckets</i>	<i>\$25.00</i>
Total Equipment Expenses (add totals of each purchase)		(E2)

Sheep Purchases

Sheep purchases include any purchase of new animals during this year. These types of purchases include purchase of Market Lambs, Ewes, Lambs, and Rams. Please list the date purchased, a description of the sheep, and the cost.

Date	Item Description	Cost/Price
9/20/10	1 Romney yearling ewe	\$200.00
Total Sheep Purchases Expenses (add totals of each purchase)		(E3)

Miscellaneous Expenses

The expenses in this category should not be able to fall within any of the previous sections. Expenses in this section can include but are not limited to vet fees, fencing costs, service costs, shearing costs, etc. Please write down the date, description, and cost of the expense.

Date	Expense Description	Cost/Price
9/25/10	Vet Fees	\$100.00
Total Miscellaneous Expenses (add totals of each purchase)		(E4)

Total Expenses

To calculate your total expenses take the totals from each of the 4 sections and add them together to get the total dollar amount of expenses.

Feed Expenses (E1)pg 8	
Equipment Expenses (E2)pg 8	
Sheep Purchases (E3)pg 9	
Misc. Expenses (E4)pg 9	
Total Expenses	(E5)



Income

Income is the amount of money that you gain from various sales regarding your sheep project. Income can be split into two main categories for this record book: Sheep Sales and Miscellaneous Income. A description of each is provided at the beginning of each section.

Sheep Sales

Sheep sales is the sale of any of your sheep in return for money. This includes the sale of any sheep including Market Lambs sold the prior 4-H year.

Date	Animal Description	Income
9/30/10	1 Dorset Ewe lamb	\$225
Total Sheep Income (add the totals form each sale)		(1)

Miscellaneous Income

Miscellaneous income is any form of money being received due to a sale of something that is not a animal but a result of your sheep project such as a wool sale. Some more examples include premiums won, fleece sales, project related item sales, etc.

Date	Income Description	Income
10/5/10	Sold 5 10-lb fleeces	\$25
Total Miscellaneous Income (add the totals form each sale)		(12)

Total Income

To calculate your total income take the totals from each of the 2 sections and add them together to get the total dollar amount of income.

Sheep Sales (1)pg 10	
Misc. Income (12)pg 10	
Total Income	(13)



Net Project Profit or Cost

To calculate your total net cost or profit you must subtract Total Expenses (E5)pg 9 from Total Income (I3)pg 10. Do not worry if your project did not yield a profit this year. Most likely your project cost more than it earned. Please do the calculation below and circle whether you made a net profit or had a net loss. While a business aims to make a profit the point of a 4-H project is to learn about your project.

Financial Summary Table

Total Income (I3) pg. 10	
Total Expenses (E5) pg. 9	
Net Project Profit or Loss	

Wool/Fleece Records

Use this section of the record book if you have a fleece or wool project and make some form of income from the sale of your fleece. Record the weight of each fleece and the income made from that fleece if the fleece was sold. If you do not have a wool project please record the date that your flock was shorn.

Animal Name of Flock #	Breed	Date Shorn	Fleece Quality	Fleece Weight	Income
Total Income from Fleece (add the income and put the number in this box)					

Ewe Production Record

This form is a more detailed version of sheep breeding record on page 13. For this page select at least one of your project ewes and fill out the pedigree for that ewe. This form should be updated each year that this ewe has lambs to determine if this ewe is a worthwhile investment.

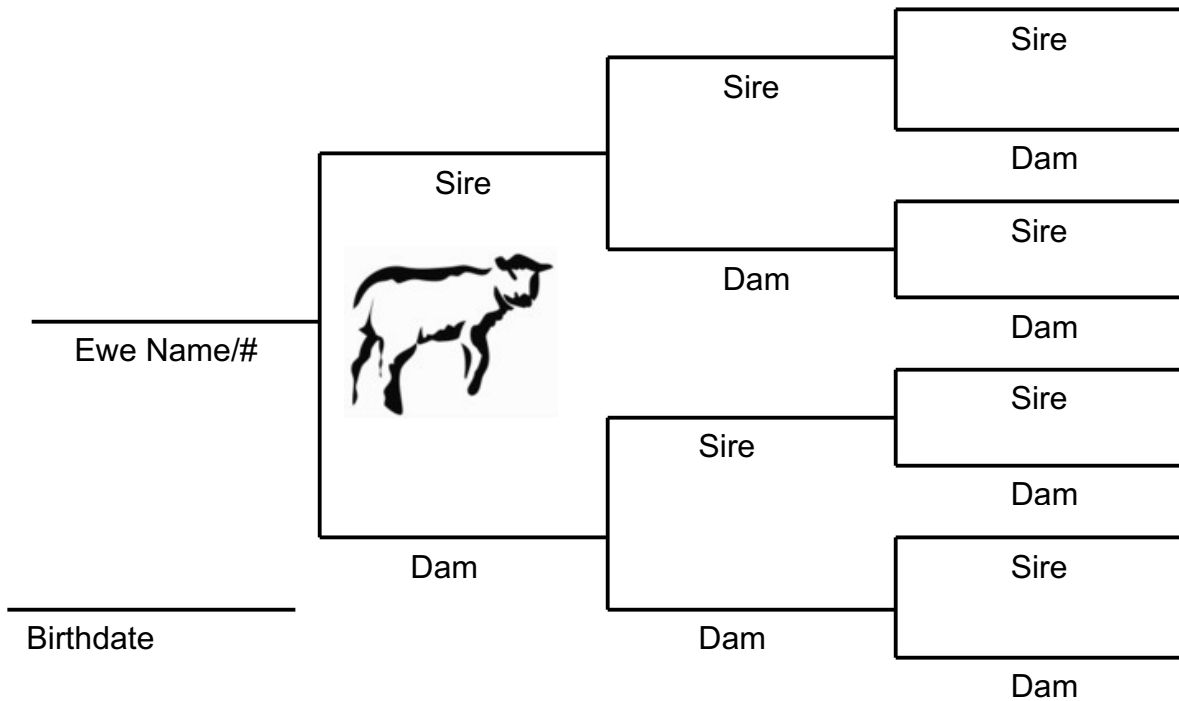

Lambing Record

Date Lambed	S,TW, TR ¹	Gender ²	Name / #	Sire	Birth Weight	Disposition (Sold or add to flock)

¹S for single, TW for twin, TR for triplet

²E for ewe, R for ram

Market Lamb Record: Weight Gain and Feed Costs

(This form is to be used for your market lamb project)

Keeping accurate weight measures and feed records is important. This form will be able to help you determine how much feed you fed your market lamb; the cost to feed your market lamb; the market lamb's rate of gain. If an animal is not fed properly no matter its genetics it will not reach its full potential as a market animal. Please fill out the information below. If you need help on calculating the costs or rates please see the next page for formulas.

Months Days/Month	March 31	March 31	April 30	May 31	June 30	July 31	Aug. 31	Totals
Starting weight (lbs)	40							
Ending weight (lbs)	71							
Total Gain/ month	31							
Avg. Daily Gain	1.0							
Lbs feed/day	2							
Lbs feed/month	62							
Cost of Feed Fed	\$10.54							
Lbs of Hay / month	20							
Cost of Hay fed / month	\$1.00							

Formulas for Market Lamb

Grain

Cost of a bag of grain: \$ _____ ÷ _____ lbs per bag = \$ _____ per lb

Amount Fed: _____ lbs per day x _____ days per month = _____ lbs per month

Monthly Cost of Grain: \$ _____ x _____ lbs =
 (Cost per lb) (lbs per month) (Monthly Cost of feed)

Hay

Cost of a bale of hay: \$ _____ ÷ _____ lbs per bale = \$ _____ per lb

Amount Fed: _____ lbs per day x _____ days per month = _____ lbs per month

Monthly Cost of Hay: _____ x _____ lbs =
 (Cost per lb) (Lbs per month) (Monthly Cost of Hay)

Average Daily Gain

Average Daily Gain = Gain ÷ Days per feeding period

Total Gain per month ÷ Days per month = ADG

Ex. 30 lbs gained ÷
 30 days fed
 1.00 ADG

Estimating Weight

1. Measure Circumference (C)
 with a tape measure, measure all the way around the sheep's body just behind the front legs.
2. Measure Length (L)
 Next, measure the length of the body from the shoulder to the point of the rump
3. Calculate Weight
 Now, multiply CxCxL and divide by 300 to determine the weight in lbs.

Looking Back

This section is to be completed at the end of the project year. It is meant for you to determine what you learned and gained during this year. This section deals with your goals accomplished and three most important things learned.

Goals Accomplished

Look back on the goals you set yourself at the beginning of the year. How well did you accomplish these goals? Did you achieve them all or fall short on some of them? Use this table to explain how well your goals were completed.

My Goals For This Year	Was it Reached?	If yes, How was it reached? If not, Why not?
<i>Example: I will learn how to give a public presentation</i>	YES	<i>I attended a county public presentation workshop. I had to change my topic three times before I could do well with it. I should have practiced my presentation more before I gave it to my club. I will try again next year.</i>

The three most important things I learned

List the three most important things you learned in this project this past project year.

The Three most important things I learned this 4-H year were....
1.
2.
3.

Telling My Story

Keeping in mind the knowledge and skills that you have learned during the past year, write a story explaining what you gained this past year. Use specific examples that are unique to you wherever possible. You may use extra pages if needed. A page has been provided for you if you wish to write your story but you may choose to type it as well. Attach photos or clippings on additional pages of this book if it helps tell your story better. However do not forget to label them.

4-H is proud of what 4-H members learn and sometimes likes to use excerpts of stories 4-H'ers write in 4-H publicity. If you do not want your information shared, please let us know by checking the boxes below:

- Do not use my story for any 4-H publicity.
- If you use my story, do not credit my name.

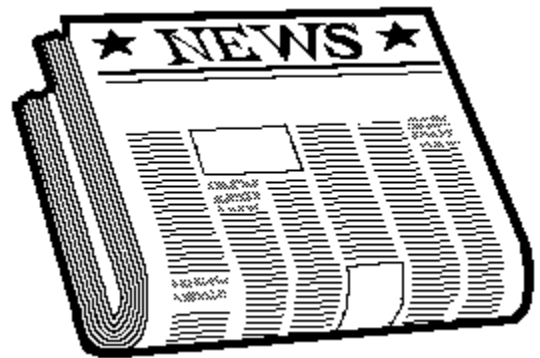

The 4-H Pledge

I PLEDGE...

...my HEAD to clearer thinking,
...my HEART to greater loyalty,
...my HANDS to larger service,
...and my HEALTH to better living,
for my club, my community,
my country, and my world

4-H Motto

"To Make The Best, Better"

4-H Slogan

"Learning by Doing"



My 4-H Story

(you may add more copies of this page if needed)

Thinking Ahead

Now is a good time to determine what you would like to learn or do the upcoming 4-H year. Please list several things that you would like to learn or do for an activity next year.

Idea for Activity or Event